

Fastening Technology / Blind Rivets

MAGNA-BULB[®] Blind Rivets



Copyright

All texts, images, technical documents and other information contained in this catalogue are subject to copyright held by Titgemeyer GmbH & Co. KG. Any reproduction or disclosure, whether as a copy or other form of duplication or use, is expressly prohibited without the prior consent of Titgemeyer GmbH & Co. KG.

Registered trademarks

The trademarks BÖRTI, GETO, GETO therm, GETOVAN, GTO, LockBolt, MEGA PORT, plasti van, PLYFIX, POLYSTIC, press-ti, RIEKO, RIV-TI, ROLL-TO, TIBOLT, TIBULB, TIFAS, TILA, TIOS and Titgemeyer are registered trademarks and the intellectual property of Titgemeyer GmbH & Co. KG.

Term of Delivery and Payment

All deliveries are carried out in compliance with our Terms of Delivery and Payment.

Limitation of liability

All technical data, performance descriptions, drawings, illustrations, measurements, weights or any other performance data, recommendations and guidelines contained in this catalogue and relating to the installation of parts that we supply are only binding if so expressly agreed. Moreover, the user is obliged at all times to check each individual use and decide whether the components that we supply can be used as needed.

We accept liability in the case of wilful intent, gross negligence and infringement of cardinal contractual duties as well as for errors in respect of express or implied representations. Notwithstanding this, any claims for compensation not explicitly agreed to in these terms and conditions are hereby excluded in the case of customers who are not consumers and, in the case of such customers, who are not consumers, at all events limited to the damage foreseeable at the time of concluding the contract as well as to the value of the delivered consignment. To the extent that our liability is excluded or limited, this shall extend accordingly to the personal liability of employees, legal representatives and vicarious agents. In all instances of gross negligence committed by vicarious agents, we shall solely be liable to customers, who are not consumers, to compensate for typically foreseeable damage. The statutory regulation governing the burden of proof shall remain unaffected. The aforementioned limitation of liability shall not apply to claims resulting from product liability, for damage resulting from injury to life, limb or health, or for damage to privately used property.

All technical specifications contained in this brochure are approximate and no guarantee is given as to their accuracy. Designs are subject to change.

Contents

Page

MAGNA-BULB® blind rivets	Overview		5
	Truss head	Steel/steel	6
	Truss head with extra-short mandrel head	Steel/steel	7

MAGNA-BULB®

blind rivets

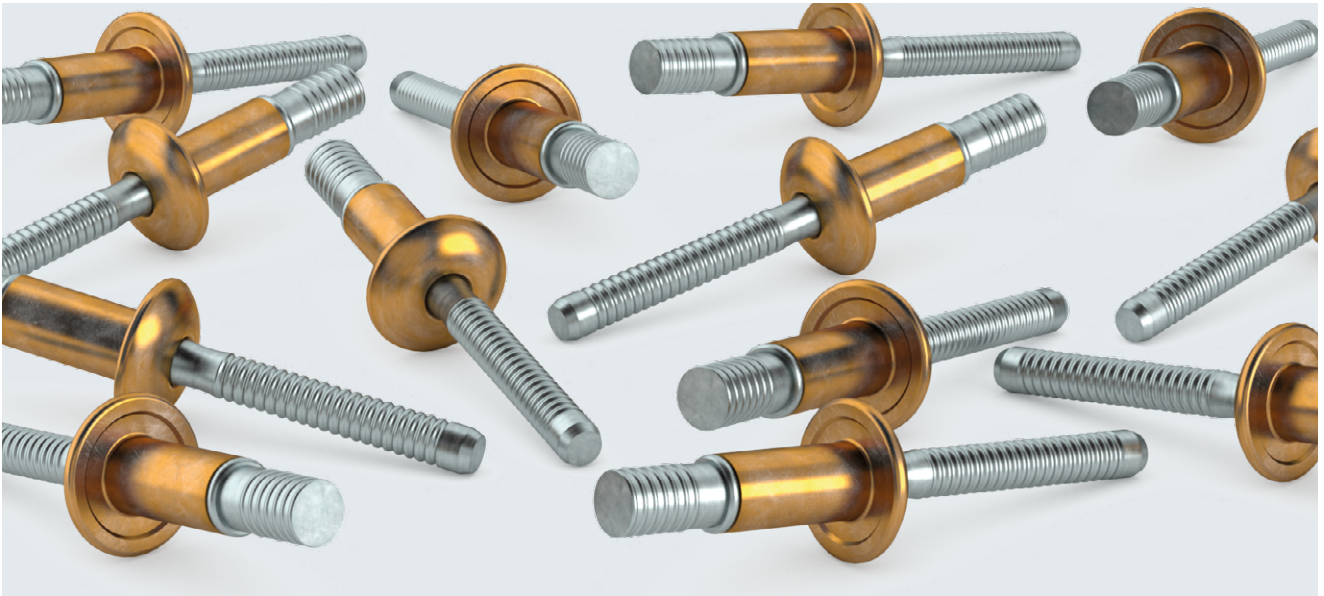

MAGNA-BULB® blind rivets stand out in particular for their large blind side footprint. This makes them a good option for installing on the rear side of thin-walled materials (including lightweight metal). As they are installed, the blind rivets exert a relatively high amount of clamp force (contact load) on the parts being joined. The full-length mandrel body ensures very high shear strengths. The mandrel is therefore securely and mechanically retained. What's more, the mandrel always breaks flush, even when materials of varying strengths and thicknesses are present within the grip range.

Benefits at a glance

- High shear and tensile strength
- The securely fitting mandrel makes for vibration-resistant applications
- Forms a large blind side footprint, very suitable for thin materials
- Mandrel always breaks off flush at the snap head
- Universal use
- Quick and secure installation
- Permanent secure fixing
- Heatless installation means component will not warp.
- Eliminates extensive refinishing

Applications

- General industry
- Steel construction and mechanical engineering
- Automotive industry
- Construction industry
- Bodywork and vehicle manufacture

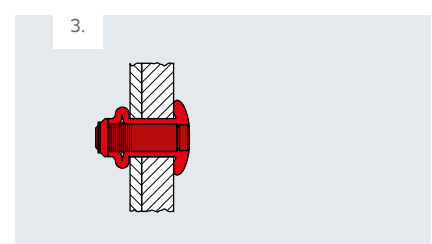
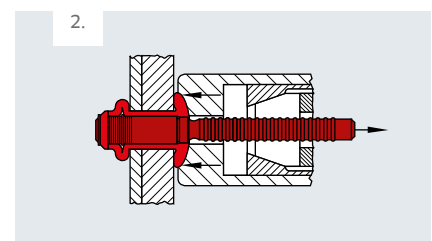
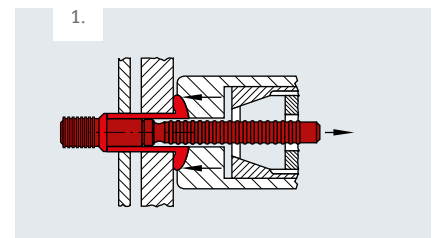

MAGNA-BULB® blind rivets

Truss head

Material

Sleeve

Steel SAE 1006,
galvanised, chromated

Mandrel

Steel SAE 10B22,
galvanised, chromated

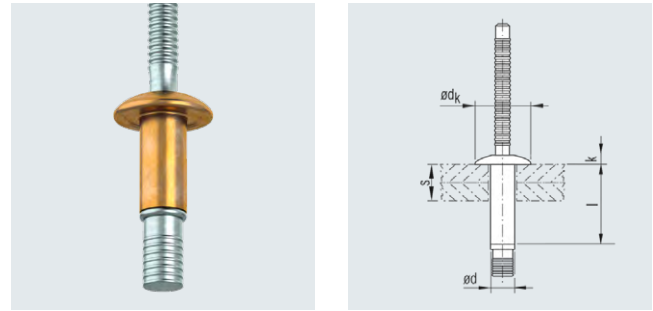

Nominal \varnothing d [mm]	Bore \varnothing [mm]	Grip range s [mm]	Blind sleeve l +1.0 -0.2 [mm]	Blind rivet head		Nominal strength at break*		Article No.
				\varnothing dk ± 0.4 [mm]	Height k ± 0.2 [mm]	Shear N	Tensile N	
4.8	4.9 - 5.1	1.9 - 2.8	15.0	9.5	2.4	8450	4670	415 242 900
		2.2 - 3.8	17.1	9.5	2.4	8450	4670	415 243 900
		3.2 - 4.8	17.7	9.5	2.4	8450	4670	415 244 900
		4.2 - 5.8	18.6	9.5	2.4	8450	4670	415 245 900
		5.2 - 6.8	19.7	9.5	2.4	8450	4670	415 246 900
		6.2 - 7.8	20.7	9.5	2.4	8450	4670	415 247 900
		7.2 - 8.8	21.7	9.5	2.4	8450	4670	415 248 900
		8.2 - 9.8	22.7	9.5	2.4	8450	4670	415 249 900
		9.2 - 10.8	23.7	9.5	2.4	8450	4670	415 250 900
		6.4	6.6 - 6.9	1.5 - 3.5	19.3	13.0	3.0	11560
2.8 - 4.8	21.9			13.0	3.0	12000	8890	415 223 900
3.8 - 5.8	23.9			13.0	3.0	12270	8890	415 224 900
4.8 - 6.8	23.2			13.0	3.0	13340	8890	415 225 900
5.8 - 7.8	23.9			13.0	3.0	14230	8890	415 226 900
6.8 - 8.8	24.9			13.0	3.0	16000	8890	415 227 900
7.8 - 9.8	25.9			13.0	3.0	16000	8890	415 228 900
8.8 - 10.8	26.9			13.0	3.0	16000	8890	415 229 900
9.8 - 11.8	27.9			13.0	3.0	16000	8890	415 230 900
10.8 - 12.8	28.9			13.0	3.0	16000	8890	415 231 900
8.0	8.3 - 8.6	11.8 - 13.8	30.0	13.0	3.0	16000	8890	415 232 900
		12.8 - 14.8	30.9	13.0	3.0	16000	8890	415 233 900
8.0	8.3 - 8.6	3.8 - 6.4	28.1	16.4	3.1	22240	13160	415 263 900

* Strengths at break relate to rivet failure.

Other designs available on request.

MAGNA-BULB® blind rivets

Flat truss head with extra-short mandrel head

Material

Sleeve

Steel SAE 1006,
galvanised, chromated

Mandrel

Steel SAE 10B22,
galvanised, chromated

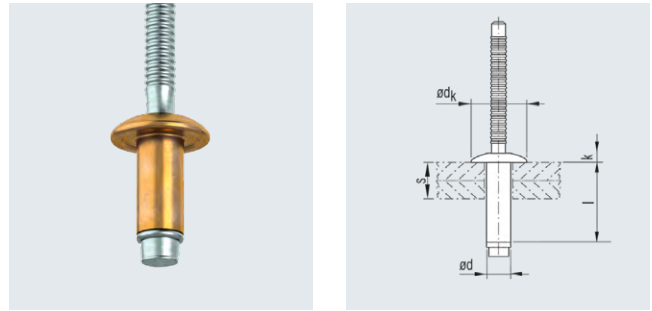

Nominal \varnothing d [mm]	Bore \varnothing [mm]	Grip range s [mm]	Blind sleeve l +1.0 -0.2 [mm]	Blind rivet head \varnothing dk ± 0.4 [mm]	Height k ± 0.2 [mm]	Nominal strength at break*		Article No.
						Shear N	Tensile N	
6.4	6.6 - 6.9	2.8 - 4.8	15.7	13.0	3.0	10670	7110	415 254 900
		4.8 - 6.8	17.0	13.0	3.0	12000	7110	415 255 900
		5.8 - 7.8	18.0	13.0	3.0	13300	7110	415 256 000
		6.8 - 8.8	19.0	13.0	3.0	13300	7110	415 257 900
		8.8 - 10.8	21.0	13.0	3.0	13300	7110	415 259 900
		10.8 - 12.8	23.0	13.0	3.0	13300	7110	415 261 900

* Strengths at break relate to rivet failure.

Other designs available on request.

About us

Titgemeyer Group is a leading fastening technology and transport technology group of companies with 15 sites across Europe. Steeped in tradition, the company develops, manufactures and sells more than 30,000 fastening elements, tools and vehicle components – in series and to customer specification.

Headquarters

Titgemeyer GmbH & Co. KG
Hannoversche Straße 97
49084 Osnabrück / DE

POB 4320
49033 Osnabrück / DE

T +49 541 5822-0
E info@titgemeyer.com
W titgemeyer.com



Sales locations

Gebr. Titgemeyer GmbH
Brunner Straße 77 - 79
1230 Wien / AT

T +43 (0) 1/6 67 90 40 - 0
E sales@titgemeyer.com
W titgemeyer.at

Titgemeyer CZ spol. s r. o.
U Vodárny 1506
397 01 Písek / CZ

T +420 382 2067 - 25
E sales@titgemeyer.com
W titgemeyercz.cz

Titgemeyer Polska sp. z o.o.
Cypriana Bazylika 17
98-200 Sieradz / PL

T +48 (0) 43 828 20 - 15
E sales@titgemeyer.com
W titgemeyer.pl

Titgemeyer Skandinavien A/S
Lunikvej 32
2670 Greve / DK

T +45 4360 0966
E info@titgemeyer.dk
W titgemeyer.dk

Titgemeyer Skandinavien A/S
Box 3218
550 03 Jönköping / SE

T +46 36 128350
E info@titgemeyer.se
W titgemeyer.se

Titgemeyer Turkey Baglanti Teknolojileri San. ve Tic. A.S.
Barbaros Mah. Is Merkezi No.1
Kat: 8 D.58
34746 Atasehir, Istanbul / TR
T +90 (0) 21 66 88 20 - 27
E sales@titgemeyer.com.tr
W titgemeyer.com.tr

Titgemeyer (UK) Limited
A2 Link One Industrial Park
George Henry Road
DY4 7BU Tipton / UK

T +44 (0) 1 21 5 57 97 - 77
E sales@titgemeyer.co.uk
W titgemeyer.co.uk

Production locations

Baker & Finmore Limited
199 Newhall Street
Birmingham, B3 1SN / UK

T +44 121 23 62 - 347
E info@bakfin.com
W bakfin.com

Titgemeyer GmbH & Co. KG Werk Lotte
Daimlerstraße 13 - 15
49504 Lotte / DE

T +49 5404 9666 - 0
E info@titgemeyer.com
W titgemeyer.com

RIEKO GmbH
Robert-Bosch-Straße 9
72124 Pliezhausen / DE

T +49 7127 9744 - 0
E info@rieko-web.com
W rieko-web.com

Titgemeyer Tools & Automation spol s.r.o.
U Vodárny 1506
397 01 Písek / CZ

T +42 382 2067 - 11
E info@rivetec.cz
W rivetec.cz

TS Gesellschaft für Transport- und Sicherungssysteme mbH
Haßlinghauser Straße 156
58285 Gevelsberg / DE

T +49 541 5822 - 900
E ts@cargocontrol.de
W wir-sind-ladungssicherung.de