

Fastening Technology / Lockbolt Systems

HUCKTAINER® Plus

Lockbolt System for Composite Materials



Copyright

All texts, images, technical documents and other information contained in this catalogue are subject to copyright held by Titgemeyer GmbH & Co. KG. Any reproduction or disclosure, whether as a copy or other form of duplication or use, is expressly prohibited without the prior consent of Titgemeyer GmbH & Co. KG.

Registered trademarks

The trademarks BÖRTI, GETO, GETO therm, GETOVAN, GTO, LockBolt, MEGA PORT, plasti van, PLYFIX, POLYSTIC, press-ti, RIEKO, RIV-TI, ROLL-TO, TIBOLT, TIBULB, TIFAS, TILA, TIOS and Titgemeyer are registered trademarks and the intellectual property of Titgemeyer GmbH & Co. KG.

Term of Delivery and Payment

All deliveries are carried out in compliance with our Terms of Delivery and Payment.

Limitation of liability

All technical data, performance descriptions, drawings, illustrations, measurements, weights or any other performance data, recommendations and guidelines contained in this catalogue and relating to the installation of parts that we supply are only binding if so expressly agreed. Moreover, the user is obliged at all times to check each individual use and decide whether the components that we supply can be used as needed.

We accept liability in the case of wilful intent, gross negligence and infringement of cardinal contractual duties as well as for errors in respect of express or implied representations. Notwithstanding this, any claims for compensation not explicitly agreed to in these terms and conditions are hereby excluded in the case of customers who are not consumers and, in the case of such customers, who are not consumers, at all events limited to the damage foreseeable at the time of concluding the contract as well as to the value of the delivered consignment. To the extent that our liability is excluded or limited, this shall extend accordingly to the personal liability of employees, legal representatives and vicarious agents. In all instances of gross negligence committed by vicarious agents, we shall solely be liable to customers, who are not consumers, to compensate for typically foreseeable damage. The statutory regulation governing the burden of proof shall remain unaffected. The aforementioned limitation of liability shall not apply to claims resulting from product liability, for damage resulting from injury to life, limb or health, or for damage to privately used property.

All technical specifications contained in this brochure are approximate and no guarantee is given as to their accuracy. Designs are subject to change.

Contents

Page

HUCKTAINER® Plus lockbolt system for composite materials	Overview		4
	Pins	Steel, zinc-plated	6
	Sleeves	Steel, zinc-plated	7

HUCKTAINER® Plus



HUCKTAINER® Plus is a two-piece fastener used in vehicle and container construction to join plywood or similar materials. Various sizes of HUCKTAINER® Pins can be chosen, depending on the thickness of the material, and installed using the HUCKTAINER® sleeve.

HUCKTAINER® Plus lockbolt system for composite materials

Criteria for selecting HUCKTAINER® sleeves:

1. For direct-tension installation on plywood or similar materials, the wide bearing sleeve, Article No. 378 250 000, is used (see Figure 1)
2. For direct-tension installation on metal-clad plywood or similar materials, or for installation on metal profiles, the narrow bearing sleeve, Article No. 378 251 000, is used (see Figure 2).

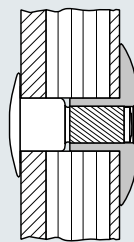

Figure 1

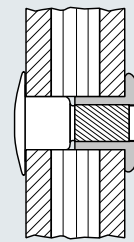

Figure 2

Criteria for selecting HUCKTAINER® sleeves

Benefits at a glance

- Fastens sandwich panels
- Extremely wide grip range (Multigrip) reduces the number of different fasteners required
- High tensile strength
- Tight-fitting
- Temperature-resistant
- Very flat and space-saving installation
- No sharp edges
- Alternative head diameters available
- Quick to install using lightweight tools. No need for cover profiles or washers.
- Corrosion-resistant, the zinc plating resists corrosion. HUCKTAINER® pins feature 10 µm zinc plating, while the colourless passivate HUCKTAINER® sleeves feature 10 µm zinc plating and yellow chromate

Applications:

- Transport technology
- Container construction

Installation steps

1. Insert pin into hole and slide sleeve onto pin-tail.
2. Press installation tool trigger. The rotating pulling head presses the sleeve onto the spiral lock of the pin.
3. The pin and sleeve lock mechanically to produce a vibration-resistant connection. The fastened parts are permanently locked together and are splash proof and waterproof.
4. The pin breaks off at the pre-determined breaking point.

An overview of recommended tools to ensure that HUCKTAINER® Plus lockbolts are perfectly fastened can be found in our lockbolt system tool catalogue - Titgemeyer/10058E.

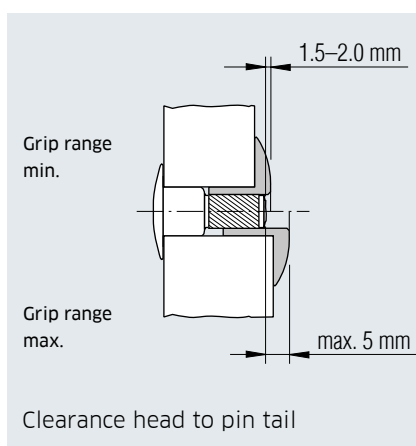
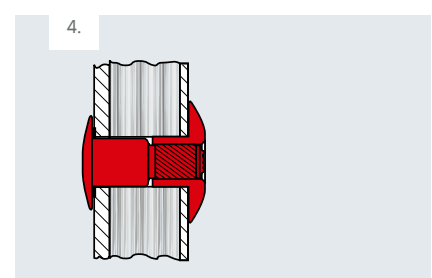
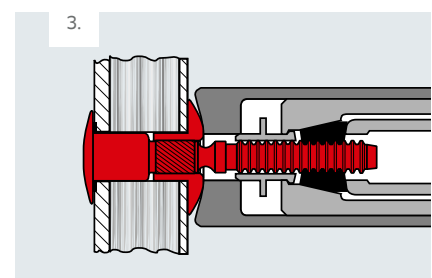
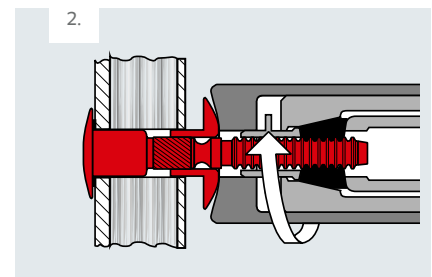
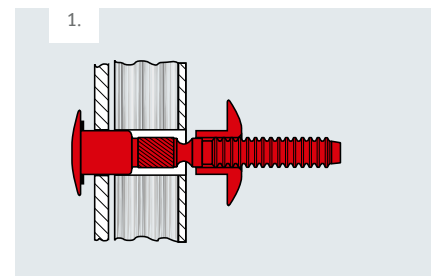

HUCKTAINER® Plus

Pins with liquid seal

Material

Steel, zinc-plated 1.5508 (AISI 10B22) min 10 µm clear chromate

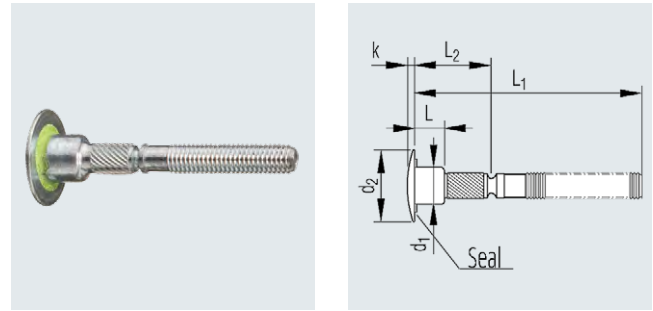

Nominal bolt \varnothing [mm]	Hole \varnothing [mm]	Grip range							Tensile strength nom [N]	Article No.
		s [mm]	L nom [mm]	L1 nom [mm]	L2 nom [mm]	d1 nom [mm]	d2 max [mm]	k max [mm]		
9.5	10.3 - 10.7	14,3 - 17,5	3.2	58.5	16.0	10.0	21.2	3.7	3560	378 230 900
		15,9 - 19,0	4.0	60.1	17.6	10.0	21.2	3.7	3560	378 231 900
		17,5 - 20,6	5.6	61.7	19.2	10.0	21.2	3.7	3560	378 232 900
		19,0 - 22,2	6.7	63.2	20.8	10.0	21.2	3.7	3560	378 233 900
		20,6 - 23,8	8.8	64.8	22.4	10.0	21.2	3.7	3560	378 234 900
		22,2 - 25,4	10.4	66.4	24.0	10.0	21.2	3.7	3560	378 235 900
		23,8 - 27,0	11.9	68.0	25.5	10.0	21.2	3.7	3560	378 236 900
		25,4 - 28,6	13.5	69.6	27.1	10.0	21.2	3.7	3560	378 237 900
		27,0 - 30,2	15.1	71.2	28.7	10.0	21.2	3.7	3560	378 238 900
		28,6 - 31,7	16.7	72.8	30.3	10.0	21.2	3.7	3560	378 239 900
		30,2 - 33,3	18.3	74.4	31.9	10.0	21.2	3.7	3560	378 240 900
		33,3 - 36,5	19.9	77.5	35.1	10.0	21.2	3.7	3560	378 242 900

Please order sleeves separately!

Other designs available on request.

HUCKTAINER® Plus

Sleeves

Material

Steel, zinc-plated, 1.1121(AISI1010), min. 10 µm clear chromate

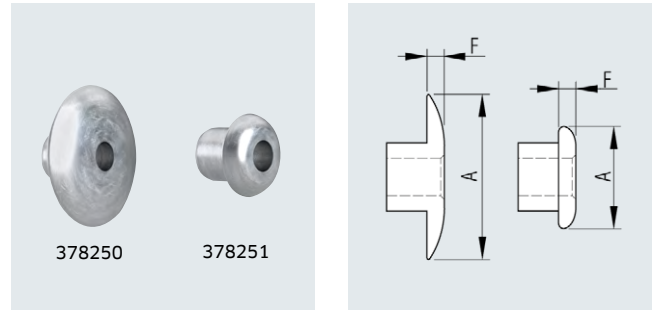

For nominal bolt ø	Head ø A max [mm]	Head height F max [mm]	Article No.
9.5	16.1	3.7	378 251 900
	29.6	3.7	378 250 900

Other designs available on request.

About us

Titgemeyer Group is a leading fastening technology and transport technology group of companies with 15 sites across Europe. Steeped in tradition, the company develops, manufactures and sells more than 30,000 fastening elements, tools and vehicle components – in series and to customer specification.

Headquarters

Titgemeyer GmbH & Co. KG
Hannoversche Straße 97
49084 Osnabrück / DE

POB 4320
49033 Osnabrück / DE

T +49 541 5822-0
E info@titgemeyer.com
W titgemeyer.com



Sales locations

Gebr. Titgemeyer GmbH
Brunner Straße 77 - 79
1230 Wien / AT

T +43 (0) 1/6 67 90 40 - 0
E sales@titgemeyer.com
W titgemeyer.at

Titgemeyer CZ spol. s r. o.
U Vodárny 1506
397 01 Písek / CZ

T +420 382 2067 - 25
E sales@titgemeyer.com
W titgemeyercz.cz

Titgemeyer Polska sp. z o.o.
Cypriana Bazylika 17
98-200 Sieradz / PL

T +48 (0) 43 828 20 - 15
E sales@titgemeyer.com
W titgemeyer.pl

Titgemeyer Skandinavien A/S
Lunikvej 32
2670 Greve / DK

T +45 4360 0966
E info@titgemeyer.dk
W titgemeyer.dk

Titgemeyer Skandinavien A/S
Box 3218
550 03 Jönköping / SE

T +46 36 128350
E info@titgemeyer.se
W titgemeyer.se

Titgemeyer Turkey Baglanti Teknolojileri San. ve Tic. A.S.
Barbaros Mah. Is Merkezi No.1
Kat: 8 D.58
34746 Atasehir, Istanbul / TR

T +90 (0) 21 66 88 20 - 27
E sales@titgemeyer.com.tr
W titgemeyer.com.tr

Titgemeyer (UK) Limited
A2 Link One Industrial Park
George Henry Road
DY4 7BU Tipton / UK

T +44 (0) 1 21 5 57 97 - 77
E sales@titgemeyer.co.uk
W titgemeyer.co.uk

Production locations

Baker & Finnemore Limited
199 Newhall Street
Birmingham, B3 1SN / UK

T +44 121 23 62 - 347
E info@bakfin.com
W bakfin.com

Titgemeyer GmbH & Co. KG Werk Lotte
Daimlerstraße 13 - 15
49504 Lotte / DE

T +49 5404 9666 - 0
E info@titgemeyer.com
W titgemeyer.com

RIEKO GmbH
Robert-Bosch-Straße 9
72124 Pliezhausen / DE

T +49 7127 9744 - 0
E info@rieko-web.com
W rieko-web.com

Titgemeyer Tools & Automation spol s.r.o.
U Vodárny 1506
397 01 Písek / CZ

T +42 382 2067 - 11
E info@rivetec.cz
W rivetec.cz

TS Gesellschaft für Transport- und Sicherungssysteme mbH
Haßlinghauser Straße 156
58285 Gevelsberg / DE

T +49 541 5822 - 900
E ts@cargocontrol.de
W wir-sind-ladungssicherung.de