

# POLYSTIC<sup>®</sup> Weld Studs





# Contents

Page

POLYSTIC® weld studs	Overview	Overview	Overview	4
	Weld studs	with metric thread, Type PT	Steel 4.8	6
A2 stainless steel			8	
Aluminium			10	
with metric thread and flange, Type PS		Steel 4.8	12	
		A2 stainless steel	13	
		A4 stainless steel	14	
Coarse thread studs	fir-tree studs, Type T5	Steel 4.8	15	
		A2 stainless steel	16	
		Aluminium	17	
	fir-tree studs, flanged T-thread	Steel 4.8	18	
A2 stainless steel		19		
Weld-on tabs	6.3 mm, single-end	Stainless steel	20	
	6.3 mm, double-end	Stainless steel	21	
Weld studs	with internal thread, cylindrical, smooth, Type IT	Steel 4.8	22	
		A2 stainless steel	23	
	cylindrical, smooth, Type UT	Steel 4.8	24	
		A2 stainless steel	25	
	cylindrical, smooth, Type US	Steel 4.8	26	
		A2 stainless steel	27	
	with metric paint-clearing thread and flange	Steel 4.8	28	
		Steel 8.8	29	
Large flange grounding studs	with metric thread and open-end flange nut	Steel 8.8	30	
		Steel 8.8	31	
ARC large flange grounding studs	with metric thread and cap	Steel 8.8	32	
		A2 stainless steel	33	

# POLYSTIC® weld studs



## Versatile design possibilities

- Very little warping due to exceptionally short welding time
- No drilling-related leaks
- High strength due to full surface join
- Access required from one side of the component only
- Welding also possible on very thin components
- Various materials can be combined

## Unrivalled cost-effectiveness

- Extremely automatable
- Very short welding times (1 ms -1.5 sec.) make for high cycle sequences
- Quick and easy use improves productivity
- No need for secondary operations on the reverse side of coated or high-alloy panels
- Low-cost standard bolts

### Examples and applications:

- Vehicle construction  
(transportation systems)
- Constructions
- Metal manufactured products
- Climate controls
- Ship-building
- Trades / household appliances

### Benefits of arc welding

- No drilling
- No punching or stamping
- No threading
- No bolting

### Installation steps

1. Align the weld bolt or stud to its desired position
2. Draw a pilot arc and burn off any dirt or contaminants
3. Apply the main arc
4. Cool down the weld pool
5. The stud is welded in place, ready for painting

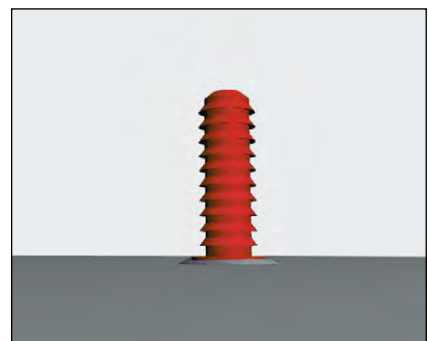
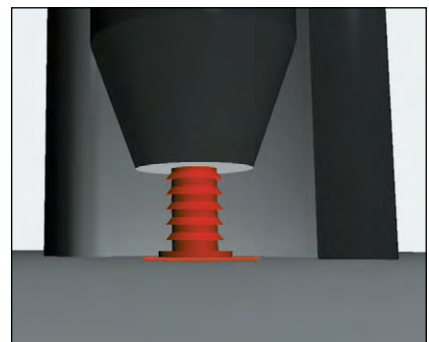
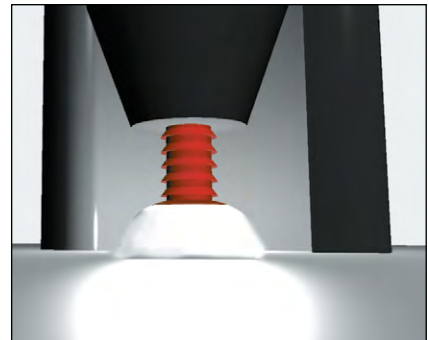
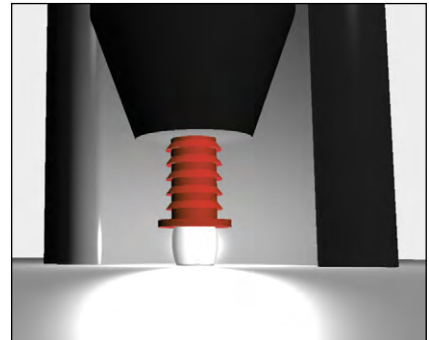
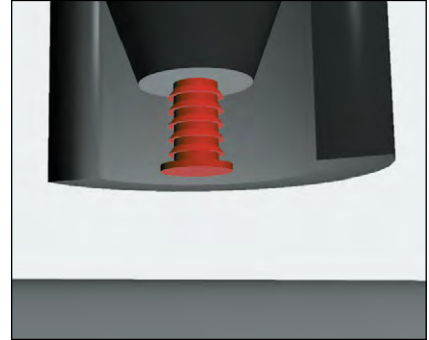

# POLYSTIC® weld studs

Weld studs with metric thread, Type PT, for capacitor discharge (CD) stud welding

### Material

Steel (4.8) copper-plated finish

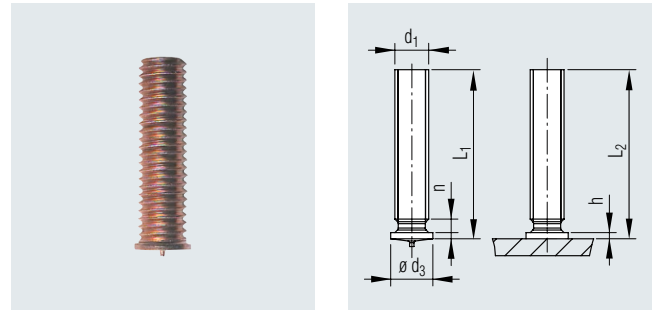

Thread size d1	Stud length L1 [mm]	Flange Ø d3 ±0.2 [mm]	Flange height h [mm]	Thread runout n max. [mm]	Stud length after welding L2 [mm]	Article No.
M4	6.0	5.5	0.7 - 1.4	1.0	L1-0.3	434 323 002
	8.0	5.5	0.7 - 1.4	1.0	L1-0.3	434 324 002
	10.0	5.5	0.7 - 1.4	1.0	L1-0.3	434 325 002
	12.0	5.5	0.7 - 1.4	1.0	L1-0.3	434 326 002
	15.0	5.5	0.7 - 1.4	1.0	L1-0.3	434 327 002
	16.0	5.5	0.7 - 1.4	1.0	L1-0.3	434 328 002
	20.0	5.5	0.7 - 1.4	1.0	L1-0.3	434 330 002
	25.0	5.5	0.7 - 1.4	1.0	L1-0.3	434 332 002
M5	6.0	7.0	0.8 - 1.4	2.0	L1-0.3	
	8.0	7.0	0.8 - 1.4	2.0	L1-0.3	434 344 002
	10.0	7.0	0.8 - 1.4	2.0	L1-0.3	434 345 002
	12.0	7.0	0.8 - 1.4	2.0	L1-0.3	434 346 002
	15.0	7.0	0.8 - 1.4	2.0	L1-0.3	434 347 002
	16.0	7.0	0.8 - 1.4	2.0	L1-0.3	434 348 002
	20.0	7.0	0.8 - 1.4	2.0	L1-0.3	434 350 002
	25.0	7.0	0.8 - 1.4	2.0	L1-0.3	434 352 002
	30.0	7.0	0.8 - 1.4	2.0	L1-0.3	434 353 002
	35.0	7.0	0.8 - 1.4	2.0	L1-0.3	434 354 002
M6	8.0	7.5	0.8 - 1.4	2.0	L1-0.3	434 364 002
	10.0	7.5	0.8 - 1.4	2.0	L1-0.3	434 365 002
	12.0	7.5	0.8 - 1.4	2.0	L1-0.3	434 366 002
	15.0	7.5	0.8 - 1.4	2.0	L1-0.3	434 367 002
	16.0	7.5	0.8 - 1.4	2.0	L1-0.3	434 368 002
	20.0	7.5	0.8 - 1.4	2.0	L1-0.3	434 370 002
	25.0	7.5	0.8 - 1.4	2.0	L1-0.3	434 372 002
	30.0	7.5	0.8 - 1.4	2.0	L1-0.3	434 373 002
	35.0	7.5	0.8 - 1.4	2.0	L1-0.3	434 374 002
	40.0	7.5	0.8 - 1.4	2.0	L1-0.3	434 375 002
	45.0	7.5	0.8 - 1.4	2.0	L1-0.3	434 376 002
	50.0	7.5	0.8 - 1.4	2.0	L1-0.3	434 377 002

Other designs available on request.

Continued on next page



## POLYSTIC® weld studs

Cont'd

Thread size d1	Stud length L1 [mm]	Flange Ø d3 ±0.2 [mm]	Flange height h [mm]	Thread runout n max. [mm]	Stud length after welding L2 [mm]	Article No.
M8	10.0	11.0	0.8 - 1.4	2.0	L1-0.3	434 382 002
	15.0	11.0	0.8 - 1.4	2.0	L1-0.3	434 384 002
	16.0	11.0	0.8 - 1.4	2.0	L1-0.3	434 395 002
	20.0	11.0	0.8 - 1.4	2.0	L1-0.3	434 386 002
	25.0	11.0	0.8 - 1.4	2.0	L1-0.3	434 388 002
	30.0	11.0	0.8 - 1.4	2.0	L1-0.3	434 389 002
	35.0	11.0	0.8 - 1.4	2.0	L1-0.3	434 390 002
	40.0	11.0	0.8 - 1.4	2.0	L1-0.3	
	50.0	11.0	0.8 - 1.4	2.0	L1-0.3	434 393 002
M10	25.0	11.0	0.8 - 1.4	2.0	L1-0.3	
	30.0	11.0	0.8 - 1.4	2.0	L1-0.3	434 413 001

Please note: Not all dimensions or materials in stock

On request: other dimensions, strengths and finishes

Other materials for product

When using weld studs with dissimilar material (e.g. S 235 / 1.4301), the products may not install correctly. It is strongly recommended that you perform appropriate welding tests prior to beginning the installation work to determine if the desired strengths and corrosion properties can be achieved with the combination of materials selected.

# POLYSTIC® weld studs

Weld studs with metric thread, Type PT,  
for capacitor discharge (CD) stud welding

**Material**

1.4301 or 1.4303 (A2-50) stainless steel 

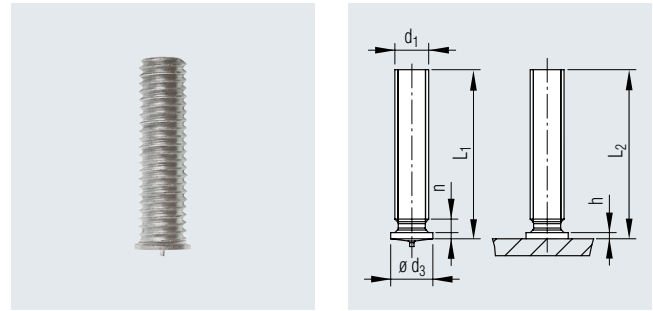

Thread size d1	Stud length L1 [mm]	Flange Ø d3 ±0.2 [mm]	Flange height h [mm]	Thread runout n max. [mm]	Stud length after welding L2 [mm]	Article No.
M4	6.0	5.5	0.7 - 1.4	1.0	L1-0.3	
	8.0	5.5	0.7 - 1.4	1.0	L1-0.3	434 524 002
	10.0	5.5	0.7 - 1.4	1.0	L1-0.3	434 525 002
	12.0	5.5	0.7 - 1.4	1.0	L1-0.3	434 526 002
	15.0	5.5	0.7 - 1.4	1.0	L1-0.3	434 527 002
	16.0	5.5	0.7 - 1.4	1.0	L1-0.3	434 528 002
	20.0	5.5	0.7 - 1.4	1.0	L1-0.3	434 530 002
	25.0	5.5	0.7 - 1.4	1.0	L1-0.3	434 532 002
M5	6.0	7.0	0.8 - 1.4	2.0	L1-0.3	434 543 002
	8.0	7.0	0.8 - 1.4	2.0	L1-0.3	434 544 002
	10.0	7.0	0.8 - 1.4	2.0	L1-0.3	434 545 002
	12.0	7.0	0.8 - 1.4	2.0	L1-0.3	434 546 002
	15.0	7.0	0.8 - 1.4	2.0	L1-0.3	434 547 002
	16.0	7.0	0.8 - 1.4	2.0	L1-0.3	434 548 002
	20.0	7.0	0.8 - 1.4	2.0	L1-0.3	434 550 002
	25.0	7.0	0.8 - 1.4	2.0	L1-0.3	434 455 002
	30.0	7.0	0.8 - 1.4	2.0	L1-0.3	434 553 002
	35.0	7.0	0.8 - 1.4	2.0	L1-0.3	434 554 002
M6	8.0	7.5	0.8 - 1.4	2.0	L1-0.3	434 564 002
	10.0	7.5	0.8 - 1.4	2.0	L1-0.3	434 565 002
	12.0	7.5	0.8 - 1.4	2.0	L1-0.3	434 566 002
	15.0	7.5	0.8 - 1.4	2.0	L1-0.3	434 567 002
	16.0	7.5	0.8 - 1.4	2.0	L1-0.3	434 568 002
	20.0	7.5	0.8 - 1.4	2.0	L1-0.3	434 570 002
	25.0	7.5	0.8 - 1.4	2.0	L1-0.3	434 572 002
	30.0	7.5	0.8 - 1.4	2.0	L1-0.3	434 573 002
	35.0	7.5	0.8 - 1.4	2.0	L1-0.3	434 574 002
	40.0	7.5	0.8 - 1.4	2.0	L1-0.3	434 575 002
	45.0	7.5	0.8 - 1.4	2.0	L1-0.3	
	50.0	7.5	0.8 - 1.4	2.0	L1-0.3	434 577 002

Other designs available on request.

Continued on next page



## POLYSTIC® weld studs

Cont'd

Thread size d1	Stud length L1 [mm]	Flange Ø d3 ±0.2 [mm]	Flange height h [mm]	Thread runout n max. [mm]	Stud length after welding L2 [mm]	Article No.
M8	10.0	11.0	0.8 - 1.4	2.0	L1-0.3	434 584 002
	12.0	11.0	0.8 - 1.4	2.0	L1-0.3	434 585 002
	15.0	11.0	0.8 - 1.4	2.0	L1-0.3	434 586 002
	16.0	11.0	0.8 - 1.4	2.0	L1-0.3	434 595 002
	20.0	11.0	0.8 - 1.4	2.0	L1-0.3	434 587 002
	25.0	11.0	0.8 - 1.4	2.0	L1-0.3	434 588 002
	30.0	11.0	0.8 - 1.4	2.0	L1-0.3	434 589 002
	35.0	11.0	0.8 - 1.4	2.0	L1-0.3	434 590 002
	40.0	11.0	0.8 - 1.4	2.0	L1-0.3	434 591 002
	50.0	11.0	0.8 - 1.4	2.0	L1-0.3	
M10	25.0	11.0	0.8 - 1.4	2.0	L1-0.3	434 607 000
	30.0	11.0	0.8 - 1.4	2.0	L1-0.3	

Please note: Not all dimensions or materials in stock

On request: other dimensions, strengths and finishes

Other materials for product

When using weld studs with dissimilar material (e.g. S 235 / 1.4301), the products may not install correctly. It is strongly recommended that you perform appropriate welding tests prior to beginning the installation work to determine if the desired strengths and corrosion properties can be achieved with the combination of materials selected.

# POLYSTIC® weld studs

Weld studs with metric thread, Type PT, for capacitor discharge (CD) stud welding

### Material

Aluminium ENAW-AlMg 3

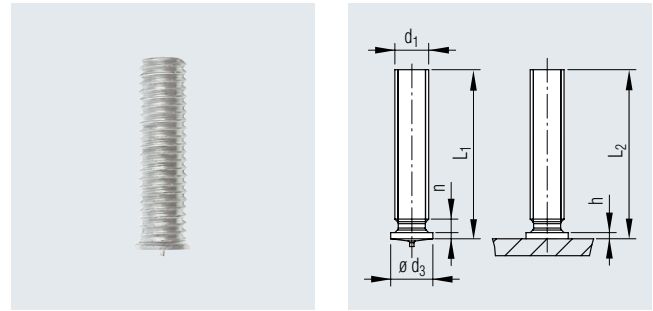

Thread size d1	Stud length L1 [mm]	Flange Ø d3 ±0.2 [mm]	Flange height h [mm]	Thread runout n max. [mm]	Stud length after welding L2 [mm]	Article No.
M4	6.0	5.5	0.7 - 1.4	1.0	L1-0.3	
	8.0	5.5	0.7 - 1.4	1.0	L1-0.3	
	10.0	5.5	0.7 - 1.4	1.0	L1-0.3	434 425 002
	12.0	5.5	0.7 - 1.4	1.0	L1-0.3	434 426 002
	15.0	5.5	0.7 - 1.4	1.0	L1-0.3	434 427 002
	16.0	5.5	0.7 - 1.4	1.0	L1-0.3	434 428 002
	20.0	5.5	0.7 - 1.4	1.0	L1-0.3	434 430 002
	25.0	5.5	0.7 - 1.4	1.0	L1-0.3	434 432 002
M5	6.0	7.0	0.8 - 1.4	2.0	L1-0.3	
	8.0	7.0	0.8 - 1.4	2.0	L1-0.3	
	10.0	7.0	0.8 - 1.4	2.0	L1-0.3	434 445 002
	12.0	7.0	0.8 - 1.4	2.0	L1-0.3	434 446 002
	15.0	7.0	0.8 - 1.4	2.0	L1-0.3	434 447 002
	16.0	7.0	0.8 - 1.4	2.0	L1-0.3	434 448 002
	20.0	7.0	0.8 - 1.4	2.0	L1-0.3	
	25.0	7.0	0.8 - 1.4	2.0	L1-0.3	434 452 002
	30.0	7.0	0.8 - 1.4	2.0	L1-0.3	
35.0	7.0	0.8 - 1.4	2.0	L1-0.3		
M6	8.0	7.5	0.8 - 1.4	2.0	L1-0.3	
	10.0	7.5	0.8 - 1.4	2.0	L1-0.3	
	12.0	7.5	0.8 - 1.4	2.0	L1-0.3	434 466 000
	15.0	7.5	0.8 - 1.4	2.0	L1-0.3	434 467 002
	16.0	7.5	0.8 - 1.4	2.0	L1-0.3	
	20.0	7.5	0.8 - 1.4	2.0	L1-0.3	434 470 002
	25.0	7.5	0.8 - 1.4	2.0	L1-0.3	434 471 002
	30.0	7.5	0.8 - 1.4	2.0	L1-0.3	
	35.0	7.5	0.8 - 1.4	2.0	L1-0.3	
	40.0	7.5	0.8 - 1.4	2.0	L1-0.3	
	45.0	7.5	0.8 - 1.4	2.0	L1-0.3	
	50.0	7.5	0.8 - 1.4	2.0	L1-0.3	

Other designs available on request.

Continued on next page

## POLYSTIC® weld studs

Cont'd

Thread d1	Stud length L1 [mm]	Flange Ø d3 ±0.2 [mm]	Flange height h [mm]	Thread runout n max. [mm]	Stud length after welding L2 [mm]	Article No.
M8	10.0	11.0	0.8 - 1.4	2.0	L1-0.3	
	12.0	11.0	0.8 - 1.4	2.0	L1-0.3	
	15.0	11.0	0.8 - 1.4	2.0	L1-0.3	
	16.0	11.0	0.8 - 1.4	2.0	L1-0.3	
	20.0	11.0	0.8 - 1.4	2.0	L1-0.3	434 486 002
	25.0	11.0	0.8 - 1.4	2.0	L1-0.3	
	30.0	11.0	0.8 - 1.4	2.0	L1-0.3	434 489 002
	35.0	11.0	0.8 - 1.4	2.0	L1-0.3	
	40.0	11.0	0.8 - 1.4	2.0	L1-0.3	
	50.0	11.0	0.8 - 1.4	2.0	L1-0.3	
M10	25.0	11.0	0.8 - 1.4	2.0	L1-0.3	
	30.0	11.0	0.8 - 1.4	2.0	L1-0.3	

Please note: Not all dimensions or materials in stock

On request: other dimensions, strengths and finishes

Other materials for product

When using weld studs with dissimilar material (e.g. S 235 / 1.4301), the products may not install correctly. It is strongly recommended that you perform appropriate welding tests prior to beginning the installation work to determine if the desired strengths and corrosion properties can be achieved with the combination of materials selected.

# POLYSTIC® weld studs

Weld studs with metric threads and flange, Type PS, for short-cycle (SC) stud welding

## Material

Steel (4.8) copper-plated finish

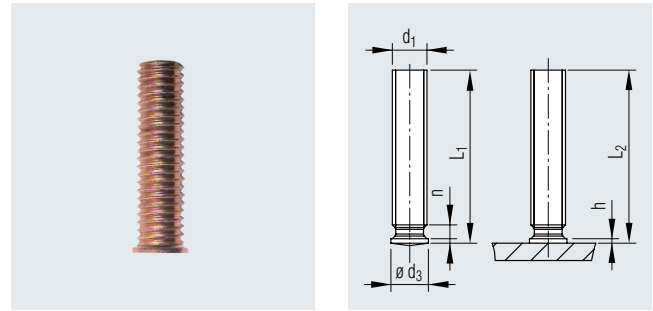

Thread size d1	Stud length L1 [mm]	Flange Ø d3 ±0.2 [mm]	Flange height h [mm]	Thread runout n max. [mm]	Stud length after welding L2 [mm]	Article No.
M5	16.0	6.0	0.8	2.0	L1-0.3	434 280 002
	12.0	6.0	0.8	2.0	L1-0.3	434 282 001
M6	15.0	7.0	0.8	2.0	L1-0.3	434 288 002
	16.0	7.0	0.8	2.0	L1-0.3	434 273 000
	20.0	7.0	0.8	2.0	L1-0.3	434 285 002
M8	12.0	9.0	1.0	2.0	L1-0.3	434 383 001
	15.0	9.0	1.0	2.0	L1-0.3	434 385 001
	16.0	9.0	1.0	2.0	L1-0.3	434 278 002
	20.0	9.0	1.0	2.0	L1-0.3	434 410 000
	25.0	9.0	1.0	2.0	L1-0.3	434 289 001
M10	15.0				L1-0.3	
	25.0				L1-0.3	
	30.0				L1-0.3	

Please note: Not all dimensions or materials in stock

On request: other dimensions, strengths and finishes

Other materials for product

When using weld studs with dissimilar material (e.g. S 235 / 1.4301), the products may not install correctly. It is strongly recommended that you perform appropriate welding tests prior to beginning the installation work to determine if the desired strengths and corrosion properties can be achieved with the combination of materials selected.

# POLYSTIC® weld studs

Weld studs with metric threads and flange,  
Type PS, for short-cycle (SC) stud welding

## Material

 A2 stainless steel

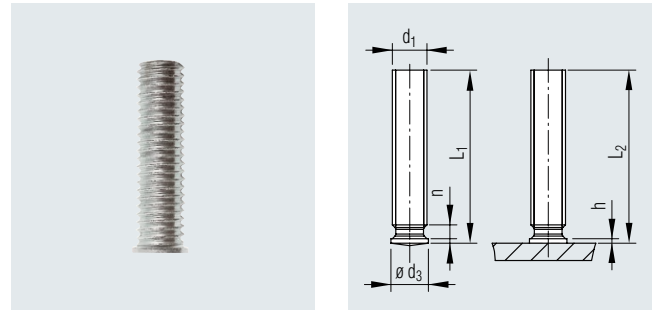

Thread size d1	Stud length L1 [mm]	Flange Ø d3 ±0.2 [mm]	Flange height h [mm]	Thread runout n max. [mm]	Stud length after welding L2 [mm]	Article No.
M5	16.0	6.0	0.8	2.0	L1-0.3	
	12.0	6.0	0.8	2.0	L1-0.3	
M6	15.0	7.0	0.8	2.0	L1-0.3	434 581 001
	16.0	7.0	0.8	2.0	L1-0.3	
	20.0	7.0	0.8	2.0	L1-0.3	434 582 001
M8	12.0	9.0	1.0	2.0	L1-0.3	
	15.0	9.0	1.0	2.0	L1-0.3	
	16.0	9.0	1.0	2.0	L1-0.3	
	20.0	9.0	1.0	2.0	L1-0.3	434 592 000
	25.0	9.0	1.0	2.0	L1-0.3	
M10	15.0				L1-0.3	
	25.0				L1-0.3	434 469 002
	30.0				L1-0.3	

Please note: Not all dimensions or materials in stock

On request: other dimensions, strengths and finishes

Other materials for product

When using weld studs with dissimilar material (e.g. S 235 / 1.4301), the products may not install correctly. It is strongly recommended that you perform appropriate welding tests prior to beginning the installation work to determine if the desired strengths and corrosion properties can be achieved with the combination of materials selected.

# POLYSTIC® weld studs

Weld studs with metric threads and flange, Type PS, for short-cycle (SC) stud welding

## Material

A4 stainless steel

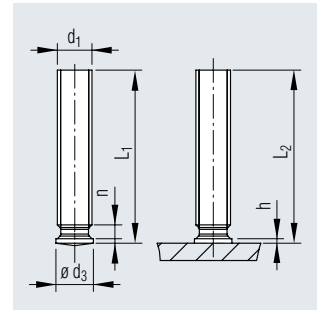
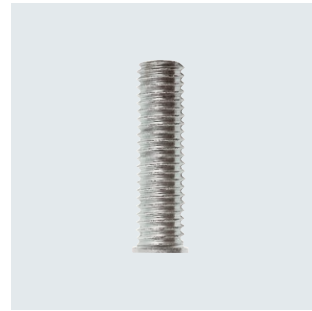

**Exceptionally high corrosion resistance**

Thread size	Stud length	Flange Ø	Flange height	Thread runout	Stud length after welding	Article No.
d1	L1	d3 ±0.2	h	n max.	L2	
	[mm]	[mm]	[mm]	[mm]	[mm]	
M5	16.0	6.0	0.8	2.0	L1-0.3	
	12.0	6.0	0.8	2.0	L1-0.3	
M6	15.0	7.0	0.8	2.0	L1-0.3	
	16.0	7.0	0.8	2.0	L1-0.3	
	20.0	7.0	0.8	2.0	L1-0.3	
M8	12.0	9.0	1.0	2.0	L1-0.3	
	15.0	9.0	1.0	2.0	L1-0.3	
	16.0	9.0	1.0	2.0	L1-0.3	
	20.0	9.0	1.0	2.0	L1-0.3	
	25.0	9.0	1.0	2.0	L1-0.3	
M10	15.0				L1-0.3	434 611 002
	25.0				L1-0.3	434 612 002
	30.0				L1-0.3	434 613 002

Please note: Not all dimensions or materials in stock

On request: other dimensions, strengths and finishes

Other materials for product

When using weld studs with dissimilar material (e.g. S 235 / 1.4301), the products may not install correctly. It is strongly recommended that you perform appropriate welding tests prior to beginning the installation work to determine if the desired strengths and corrosion properties can be achieved with the combination of materials selected.

# POLYSTIC® weld studs

Coarse thread fir-tree studs, Type T5,  
for capacitor discharge (CD) stud welding

## Material

Steel (4.8) copper-plated finish

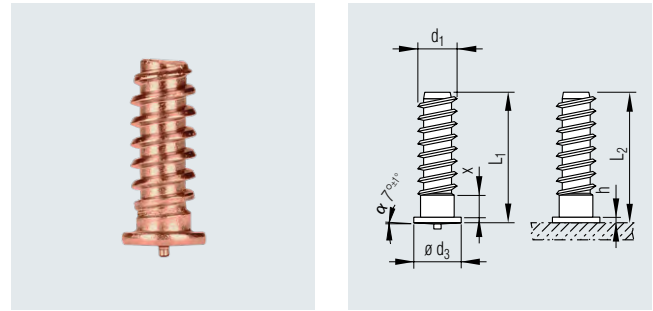

Thread size d1	Stud length L1 [mm]	Flange Ø d3 ±0.2 [mm]	Flange height h [mm]	Thread runout n max. [mm]	Stud length after welding L2 [mm]	Article No.
T5	9.0	6.5	0.7	3.0	L1-0.3	434 211 002
	12.0	6.5	0.7	3.0	L1-0.3	434 213 001
	14.0	6.5	0.7	3.0	L1-0.3	
	14.2	6.5	0.7	3.0	L1-0.3	
	16.5	6.5	0.7	3.0	L1-0.3	434 228 000
	18.0	6.5	0.7	3.0	L1-0.3	434 231 001

Please note: Not all dimensions or materials in stock

On request: other dimensions, strengths and finishes

Other materials for product

When using weld studs with dissimilar material (e.g. S 235 / 1.4301), the products may not install correctly. It is strongly recommended that you perform appropriate welding tests prior to beginning the installation work to determine if the desired strengths and corrosion properties can be achieved with the combination of materials selected.



# POLYSTIC® weld studs

Coarse thread fir-tree studs, Type T5,  
for capacitor discharge (CD) stud welding

## Material

1.4301 or 1.4303 (A2-50) stainless steel

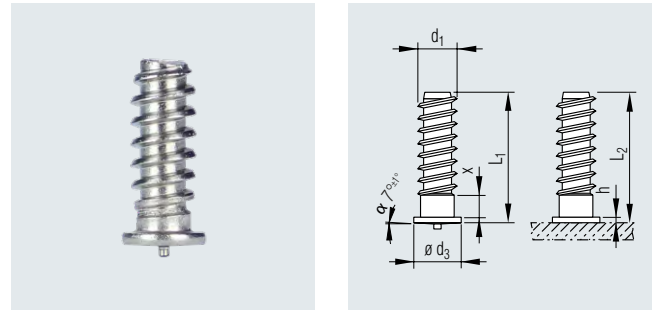

Thread size	Stud length	Flange Ø	Flange height	Thread runout	Stud length after welding	Article No.
d1	L1	d3 ±0.2	h	n max.	L2	
	[mm]	[mm]	[mm]	[mm]	[mm]	
T5	9.0	6.5	0.7	3.0	L1-0.3	434 216 001
	12.0	6.5	0.7	3.0	L1-0.3	
	14.0	6.5	0.7	3.0	L1-0.3	434 226 001
	14.2	6.5	0.7	3.0	L1-0.3	
	16.5	6.5	0.7	3.0	L1-0.3	
	18.0	6.5	0.7	3.0	L1-0.3	

Please note: Not all dimensions or materials in stock

On request: other dimensions, strengths and finishes

Other materials for product

When using weld studs with dissimilar material (e.g. S 235 / 1.4301), the products may not install correctly. It is strongly recommended that you perform appropriate welding tests prior to beginning the installation work to determine if the desired strengths and corrosion properties can be achieved with the combination of materials selected.

# POLYSTIC® weld studs

Coarse thread fir-tree studs, Type T5,  
for capacitor discharge (CD) stud welding

## Material

 Aluminium AlMg3

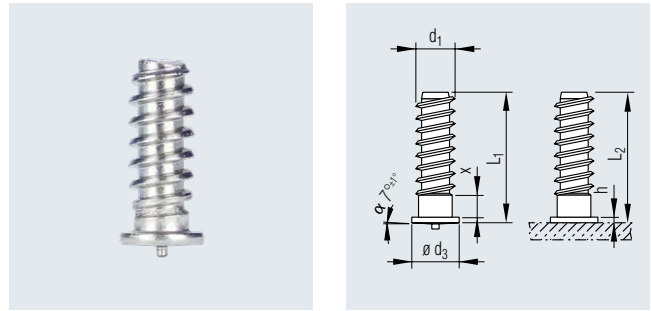

Thread size	Stud length	Flange Ø	Flange height	Thread runout	Stud length after welding	Article No.
d1	L1	d3 ±0.2	h	n max.	L2	
	[mm]	[mm]	[mm]	[mm]	[mm]	
T5	9.0	6.5	0.7	3.0	L1-0.3	
	12.0	6.5	0.7	3.0	L1-0.3	
	14.0	6.5	0.7	3.0	L1-0.3	434 225 001
	14.2	6.5	0.7	3.0	L1-0.3	
	16.5	6.5	0.7	3.0	L1-0.3	
	18.0	6.5	0.7	3.0	L1-0.3	4347 233 001

Please note: Not all dimensions or materials in stock

On request: other dimensions, strengths and finishes

Other materials used in design

When using weld studs with dissimilar material (e.g. S 235 / 1.4301), the products may not install correctly. It is strongly recommended that you perform appropriate welding tests prior to beginning the installation work to determine if the desired strengths and corrosion properties can be achieved with the combination of materials selected.

# POLYSTIC® weld studs

Coarse thread fir-tree studs, flanged T-thread, for short-cycle (SD) stud welding

## Material

 Steel (4.8) copper-plated finish

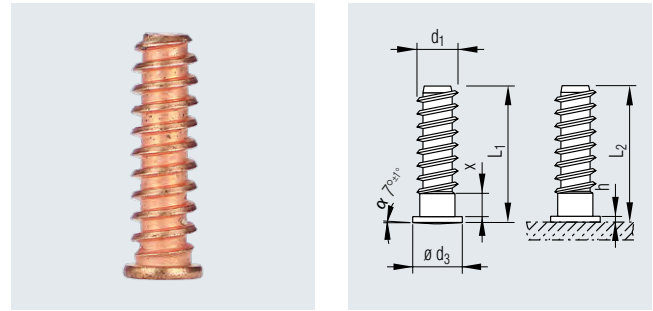

Thread size d1	Stud length L1 [mm]	Flange Ø d3 ±0.2 [mm]	Flange height h [mm]	Thread runout n max. [mm]	Stud length after welding L2 [mm]	Article No.
T5	9.0	6.0	0.7	3.0	L1-0.3	434 207 000
	12.0	6.0	0.7	3.0	L1-0.3	434 221 000
	14.2	6.0	0.7	3.0	L1-0.3	434 222 000
	15.5	6.0	0.7	3.0	L1-0.3	434 244 901
	16.0	6.0	0.7	3.0	L1-0.3	434 229 002
	16.5	6.0	0.7	3.0	L1-0.3	434 232 001
	18.0	6.0	0.7	3.0	L1-0.3	
	20.0	6.0	0.7	3.0	L1-0.3	434 238 001
	25.0	6.0	0.7	3.0	L1-0.3	434 240 002
	30.0	6.0	0.7	3.0	L1-0.3	434 260 000
T5	25.0	7.0	0.7	3.0	L1-0.3	434 286 002

Please note: Not all dimensions or materials in stock

On request: other dimensions, strengths and finishes

Other materials used in design

When using weld studs with dissimilar material (e.g. S 235 / 1.4301), the products may not install correctly. It is strongly recommended that you perform appropriate welding tests prior to beginning the installation work to determine if the desired strengths and corrosion properties can be achieved with the combination of materials selected.

# POLYSTIC® weld studs

Coarse thread fir-tree studs, flanged T-thread, for short-cycle (SD) stud welding

## Material

A2 stainless steel

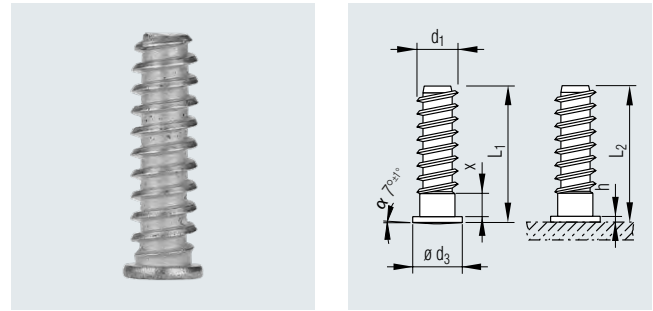

Thread size d1	Stud length L1 [mm]	Flange Ø d3 ±0.2 [mm]	Flange height h [mm]	Thread runout n max. [mm]	Stud length after welding L2 [mm]	Article No.
T5	9.0	6.0	0.7	3.0	L1-0.3	
	12.0	6.0	0.7	3.0	L1-0.3	
	14.2	6.0	0.7	3.0	L1-0.3	434 227 001
	15.5	6.0	0.7	3.0	L1-0.3	
	16.0	6.0	0.7	3.0	L1-0.3	
	16.5	6.0	0.7	3.0	L1-0.3	
	18.0	6.0	0.7	3.0	L1-0.3	
	20.0	6.0	0.7	3.0	L1-0.3	
	25.0	6.0	0.7	3.0	L1-0.3	
	30.0	6.0	0.7	3.0	L1-0.3	
T5	25.0	7.0	0.7	3.0	L1-0.3	

Please note: Not all dimensions or materials in stock

On request: other dimensions, strengths and finishes

Other materials for product

When using weld studs with dissimilar material (e.g. S 235 / 1.4301), the products may not install correctly. It is strongly recommended that you perform appropriate welding tests prior to beginning the installation work to determine if the desired strengths and corrosion properties can be achieved with the combination of materials selected.

# POLYSTIC® weld studs

Weld-on tabs, 6.3 mm, for capacitor discharge (CD) stud welding

**Material**

■ Stainless steel

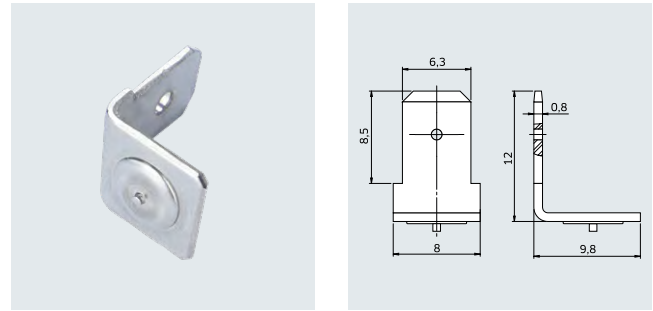

Thread type	Tab dimensions [mm]	Overall height [mm]	Width [mm]	Depth [mm]	Article No.
single-end	6.3	12.0	8.0	9.8	434 081 000

# POLYSTIC® weld studs

Weld-on tabs 6.3 mm, for capacitor discharge (CD) stud welding

## Material

■ Stainless steel

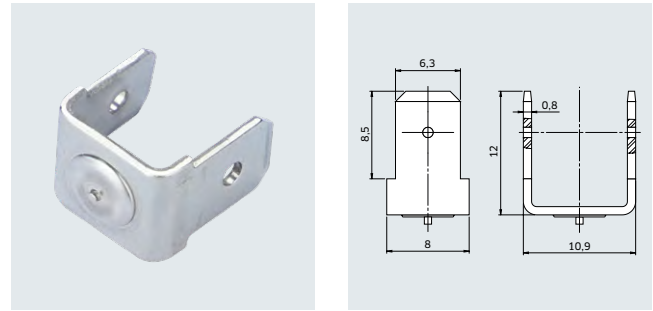

Thread type	Tab dimensions [mm]	Overall height [mm]	Width [mm]	Depth [mm]	Article No.
double-end	6.3	12.0	8.0	10.9	434 085 000

# POLYSTIC® weld studs

Weld studs with internal thread, cylindrical, smooth, Type IT, for capacitor discharge (CD) stud welding

## Material

 Steel (4.8) copper-plated finish

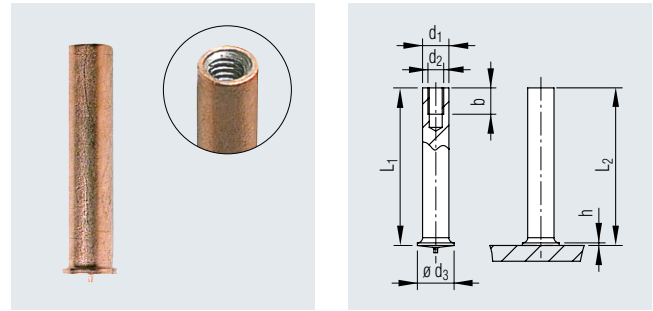

Internal thread d2	Pin length L1 [mm]	Flange Ø d3 ±0.2 [mm]	Flange height h [mm]	Outer Ø d1 [mm]	Pin length after welding L2 [mm]	Thread depth b [mm]	Article No.
M3	8.0	7.0	0.5	5.0	L1-0.3	5.0	
M4	8.0	7.5	0.6	6.0	L1-0.3	6.0	
	10.0	7.5	0.6	6.0	L1-0.3	6.0	434 820 000
	15.0	7.5	0.6	6.0	L1-0.3	6.0	434 822 002
M5	12.0	8.0	0.7	7.1	L1-0.3	7.0	434 831 000
	20.0	8.0	0.7	7.1	L1-0.3	7.0	
M6	20.0				L1-0.3		

Please note: Not all dimensions or materials in stock

On request: other dimensions, strengths and finishes

Other materials for product

When using weld studs with dissimilar material (e.g. S 235 / 1.4301), the products may not install correctly. It is strongly recommended that you perform appropriate welding tests prior to beginning the installation work to determine if the desired strengths and corrosion properties can be achieved with the combination of materials selected.



# POLYSTIC® weld studs

Weld studs with internal thread, cylindrical, smooth, Type IT, for capacitor discharge (CD) stud welding

## Material

 A2 stainless steel

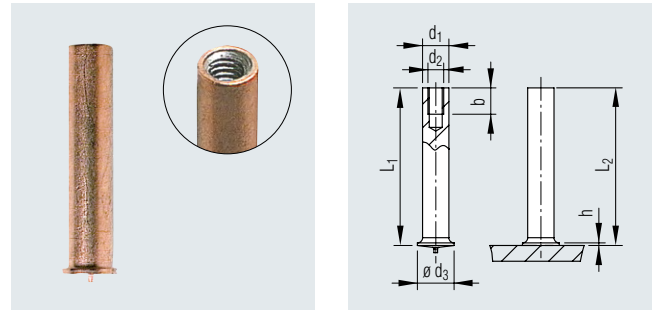

Internal thread d2	Pin length L1 [mm]	Flange Ø d3 ±0.2 [mm]	Flange height h [mm]	Outer Ø d1 [mm]	Pin length after welding L2 [mm]	Thread depth b [mm]	Article No.
M3	8.0	7.0	0.5	5.0	L1-0.3	5.0	434 840 002
M4	8.0	7.5	0.6	6.0	L1-0.3	6.0	434 850 000
	10.0	7.5	0.6	6.0	L1-0.3	6.0	
	15.0	7.5	0.6	6.0	L1-0.3	6.0	
M5	12.0	8.0	0.7	7.1	L1-0.3	7.0	434 847 002
	20.0	8.0	0.7	7.1	L1-0.3	7.0	434 865 002
M6	20.0				L1-0.3		434 880 000

Please note: Not all dimensions or materials in stock

On request: other dimensions, strengths and finishes

Other materials for product

When using weld studs with dissimilar material (e.g. S 235 / 1.4301), the products may not install correctly. It is strongly recommended that you perform appropriate welding tests prior to beginning the installation work to determine if the desired strengths and corrosion properties can be achieved with the combination of materials selected.

# POLYSTIC® weld studs

Weld studs, cylindrical, smooth  
Type UT, for capacitor (CD) stud welding

## Material

Steel (4.8) copper-plated finish

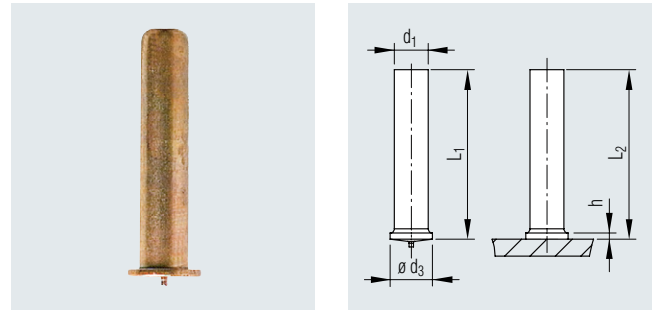

Pin Ø $d1 \pm 0.1$ [mm]	Pin length L1 [mm]	Flange Ø $d3 \pm 0.2$ [mm]	Flange height h [mm]	Pin length after welding L2 [mm]	Article No.
3.0	6.0	4.5	0.7 - 1.4	L1-0.3	
	12.0	4.5	0.7 - 1.4	L1-0.3	
	20.0	4.5	0.7 - 1.4	L1-0.3	434 905 002
5.0	16.0	6.5	0.8 - 1.4	L1-0.3	434 924 002
6.0	10.0	7.5	0.8 - 1.4	L1-0.3	
	20.0	7.5	0.8 - 1.4	L1-0.3	434 975 000
	55.0	7.5	0.8 - 1.4	L1-0.3	434 981 002

On request: other dimensions, strengths and finishes

When using weld studs with dissimilar material (e.g. S 235 / 1.4301), the products may not install correctly. It is strongly recommended that you perform appropriate welding tests prior to beginning the installation work to determine if the desired strengths and corrosion properties can be achieved with the combination of materials selected

# POLYSTIC® weld studs

Weld studs, cylindrical, smooth  
Type UT, for capacitor (CD) stud welding

## Material

 A2 stainless steel

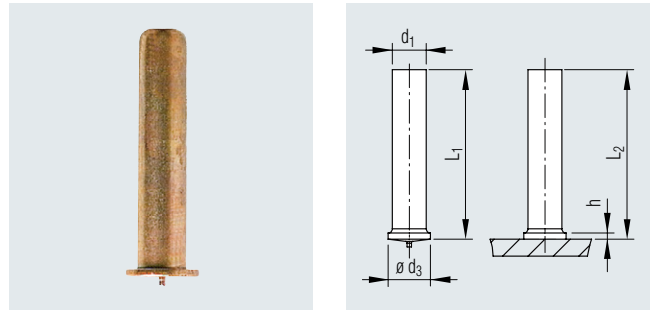

Pin Ø $d1 \pm 0.1$ [mm]	Pin length L1 [mm]	Flange Ø $d3 \pm 0.2$ [mm]	Flange height h [mm]	Pin length after welding L2 [mm]	Article No.
3.0	6.0	4.5	0.7 - 1.4	L1-0.3	434 934 002
	12.0	4.5	0.7 - 1.4	L1-0.3	434 937 002
	20.0	4.5	0.7 - 1.4	L1-0.3	
5.0	16.0	6.5	0.8 - 1.4	L1-0.3	
6.0	10.0	7.5	0.8 - 1.4	L1-0.3	434 982 002
	20.0	7.5	0.8 - 1.4	L1-0.3	
	55.0	7.5	0.8 - 1.4	L1-0.3	

On request: other dimensions, strengths and finishes

When using weld studs with dissimilar material (e.g. S 235 / 1.4301), the products may not install correctly. It is strongly recommended that you perform appropriate welding tests prior to beginning the installation work to determine if the desired strengths and corrosion properties can be achieved with the combination of materials selected.

# POLYSTIC® weld studs

Weld studs, cylindrical, smooth  
Type US, for short-cycle (SC) stud welding

**Material**

Steel (4.8) copper-plated finish

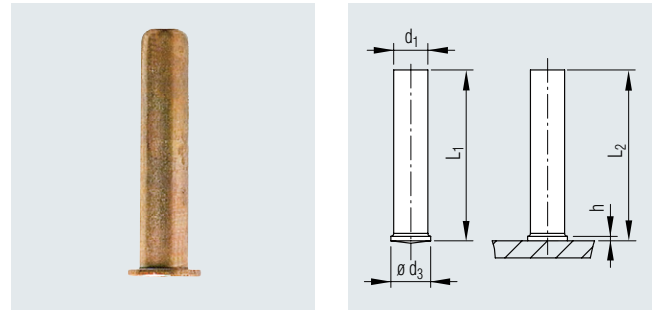

Pin Ø	Pin length	Flange Ø	Flange height	Pin length after welding	Article No.
$d1 \pm 0.1$	L1	$d3 \pm 0.2$	h	L2	
[mm]	[mm]	[mm]	[mm]	[mm]	
8.0	20.0	9.0	1.0	L1-0.3	434 987 001

On request: other dimensions, strengths and finishes

For other fasteners on weld pins, we recommend our extensive range of STARLOCK® push-on fasteners.



STARLOCK® push-on fasteners in steel or stainless steel - uncapped

STARLOCK® push-on fasteners in steel or stainless steel - capped

# POLYSTIC® weld studs

Weld studs, cylindrical, smooth  
Type US, for short-cycle (SC) stud welding

## Material

A2 stainless steel

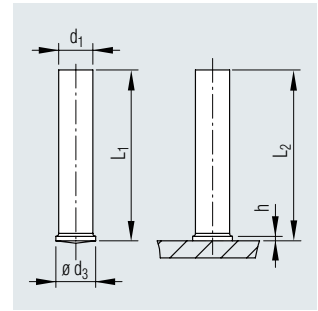

Pin Ø	Pin length	Flange Ø	Flange height	Pin length after welding	Article No.
$d1 \pm 0.1$	L1	$d3 \pm 0.2$	h	L2	
[mm]	[mm]	[mm]	[mm]	[mm]	
8.0	20.0	9.0	1.0	L1-0.3	434 969 001

On request: other dimensions, strengths and finishes

For other fasteners on weld pins, we recommend our extensive range of STARLOCK® push-on fasteners.



STARLOCK® push-on fasteners in  
steel or stainless steel - uncapped

STARLOCK® push-on fasteners in  
steel or stainless steel - capped

# POLYSTIC® weld studs

Weld studs with metric paint-clearing thread and flange, for short-cycle (SC) stud welding

### Material

 Steel (4.8) copper-plated finish

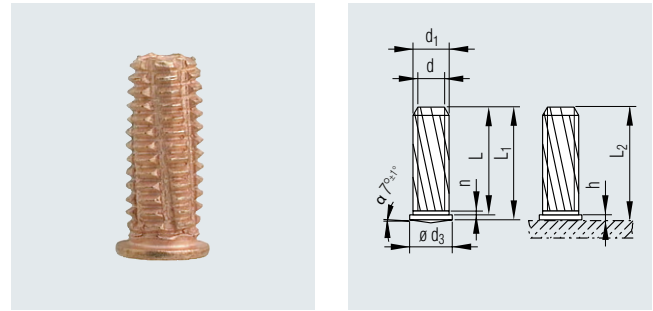

Thread size d1	Stud length L1 [mm]	Flange Ø d3 ±0.2 [mm]	Flange height h [mm]	Thread runout n max. [mm]	Stud length after welding L2 [mm]	Article No.
M6	12.0	7.0	0.8	0.8	L1-0.3	434 159 000
	16.0	7.0	0.8	0.8	L1-0.3	434 163 000
	18.0	7.0	0.8	0.8	L1-0.3	434 170 900
	20.0	7.0	0.8	0.8	L1-0.3	434 188 000
	25.0	7.0	0.8	0.8	L1-0.3	434 189 001

On request: other dimensions, materials, finishes as well as studs with land margin (diameter d1 with length L1-L)

# POLYSTIC® weld studs

Weld studs with metric paint-clearing thread and flange, for short-cycle (SC) stud welding

## Material

 Steel (8.8) copper-plated finish

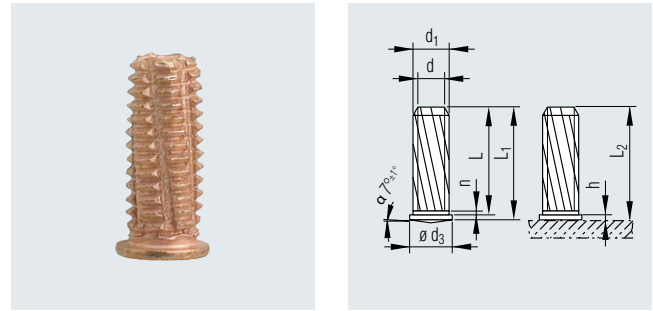

Thread size	Stud length	Flange Ø	Flange height	Thread runout	Stud length after welding	Article No.
d1	L1	d3 ±0.2	h	n max.	L2	
	[mm]	[mm]	[mm]	[mm]	[mm]	
M6	25.0	7.0	0.8	0.8	L1-0.3	434 136 001
	30.0	7.0	0.8	0.8	L1-0.3	434 134 902
	235.0	7.0	0.8	0.8	L1-0.3	434 135 900

On request: other dimensions, materials, finishes as well as studs with land margin (diameter d1 with length L1-L)



# POLYSTIC® weld studs

Large flange grounding studs with metric thread and open-end flange nut for drawn-arc or short-cycle (SC) stud welding

### Material

Steel (8.8), zinc-plated, passivated

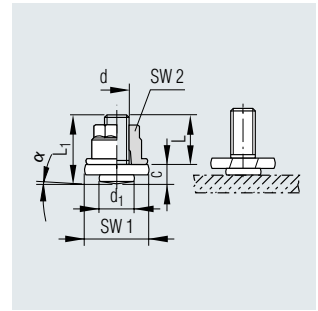

Thread size d	Thread length L ±0.2 [mm]	Stud length L1 +0.2 [mm]	Flange Ø d1 -0.5 [mm]	Flange height C ±0.2 [mm]	Overall length [mm]	Spanner size SW1	Spanner size SW2	Article No.
M6	15.0	18.0	8.0	4.0	21.2	11.0	10.0	434 258 900
M8	15.0	21.0	9.0	6.0	26.8	15.0	13.0	

On request: other dimensions and materials

## POLYSTIC® weld studs

Large flange grounding studs with metric thread and closed-end domed cap nut for drawn-arc or short-cycle (SC) stud welding

### Material

Steel (8.8), zinc-plated, passivated

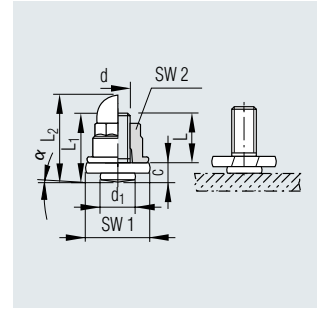

Thread size d	Thread length L ±0.2 [mm]	Stud length L1 +0.2 [mm]	Flange Ø d1 -0.5 [mm]	Flange height C ±0.2 [mm]	Overall length [mm]	Spanner size SW1	Spanner size SW2	Article No.
M6	15.0	18.0	8.0	4.0	21.2	11.0	10.0	434 197 000
M8	15.0	21.0	9.0	6.0	26.8	15.0	13.0	434 198 900

On request: other dimensions and materials

# POLYSTIC® weld studs

ARC large flange grounding studs with metric thread and cap for drawn-arc and short-cycle (SC) stud welding

### Material

 Steel (8.8), nickel-plated

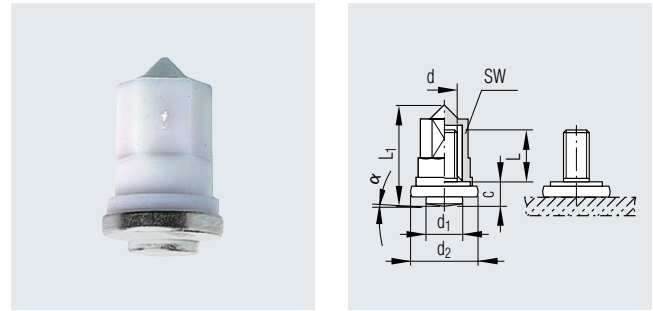

Thread size d	Thread length L [mm]	Stud length L1 +0.2 [mm]	Flange Ø d1 -0.5 [mm]	Flange height C ±0.2 [mm]	Double flange Ø d2 [mm]	Spanner size SW	Article No.
M6	12.0	23.0	8.0	5.4	14.0	10.0	
	15.0	26.0	8.0	5.4	14.0	10.0	434 292 002
M8	15.0	26.0	10.0	5.4	14.0	10.0	434 295 000

On request: Other dimensions and materials

# POLYSTIC® weld studs

ARC large flange grounding studs with metric thread and cap for drawn-arc and short-cycle (SC) stud welding

## Material

■ A2 stainless steel

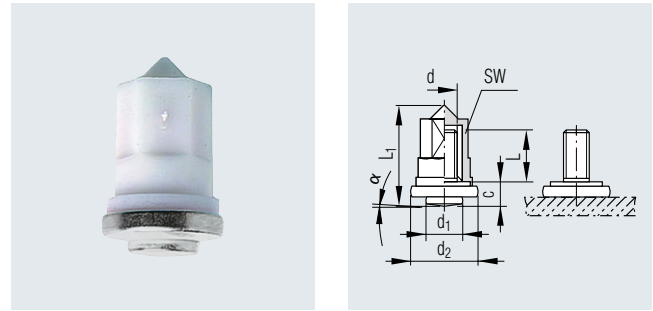

Thread size d	Thread length L [mm]	Stud length L1 +0.2 [mm]	Flange Ø d1 -0.5 [mm]	Flange height C ±0.2 [mm]	Double flange Ø d2 [mm]	Spanner size SW	Article No.
M6	12.0	23.0	8.0	5.4	14.0	10.0	434 291 000 <sup>2</sup>
	15.0	26.0	8.0	5.4	14.0	10.0	
M8	15.0	26.0	10.0	5.4	14.0	10.0	434 296 000 <sup>1,3</sup>

<sup>1</sup> Flange 8.0 mm

<sup>2</sup> Material: A2 1.4016 stainless steel

<sup>3</sup> Material: A2 1.4303 stainless steel

On request: other dimensions and materials



**Copyright**

All texts, images, technical documents and other information contained in this catalogue are subject to copyright held by Titgemeyer GmbH & Co. KG. Any reproduction or disclosure, whether as a copy or other form of duplication or use, is expressly prohibited without the prior consent of Titgemeyer GmbH & Co. KG.

**Registered trademarks**

The trademarks BÖRTI, GETO, GETO therm, GETOVAN, GTO, LockBolt, MEGA PORT, plasti van, PLYFIX, POLYSTIC, press-ti, RIEKO, RIV-TI, ROLL-TO, TIBOLT, TIBULB, TIFAS, TILA, TIOS and Titgemeyer are registered trademarks and the intellectual property of Titgemeyer GmbH & Co. KG.

**Term of Delivery and Payment**

All deliveries are carried out in compliance with our Terms of Delivery and Payment.

**Limitation of liability**

All technical data, performance descriptions, drawings, illustrations, measurements, weights or any other performance data, recommendations and guidelines contained in this catalogue and relating to the installation of parts that we supply are only binding if so expressly agreed. Moreover, the user is obliged at all times to check each individual use and decide whether the components that we supply can be used as needed.

We accept liability in the case of wilful intent, gross negligence and infringement of cardinal contractual duties as well as for errors in respect of express or implied representations. Notwithstanding this, any claims for compensation not explicitly agreed to in these terms and conditions are hereby excluded in the case of customers who are not consumers and, in the case of such customers, who are not consumers, at all events limited to the damage foreseeable at the time of concluding the contract as well as to the value of the delivered consignment. To the extent that our liability is excluded or limited, this shall extend accordingly to the personal liability of employees, legal representatives and vicarious agents. In all instances of gross negligence committed by vicarious agents, we shall solely be liable to customers, who are not consumers, to compensate for typically foreseeable damage. The statutory regulation governing the burden of proof shall remain unaffected. The aforementioned limitation of liability shall not apply to claims resulting from product liability, for damage resulting from injury to life, limb or health, or for damage to privately used property.

**All technical specifications contained in this brochure are approximate and no guarantee is given as to their accuracy. Designs are subject to change.**

## About us

Titgemeyer Group is a leading fastening technology and transport technology group of companies with 15 sites across Europe. Steeped in tradition, the company develops, manufactures and sells more than 30,000 fastening elements, tools and vehicle components – in series and to customer specification.

### Headquarters

**Titgemeyer GmbH & Co. KG**  
Hannoversche Straße 97  
49084 Osnabrück / DE

POB 4320  
49033 Osnabrück / DE

T +49 541 5822-0  
E [info@titgemeyer.com](mailto:info@titgemeyer.com)  
W [titgemeyer.com](http://titgemeyer.com)



### Sales locations

**Gebr. Titgemeyer GmbH**  
Brunner Straße 77 - 79  
1230 Wien / AT

T +43 (0) 1/6 67 90 40 - 0  
E [sales@titgemeyer.com](mailto:sales@titgemeyer.com)  
W [titgemeyer.at](http://titgemeyer.at)

**Titgemeyer CZ spol. s r. o.**  
U Vodárny 1506  
397 01 Písek / CZ

T +420 382 2067 - 25  
E [sales@titgemeyer.com](mailto:sales@titgemeyer.com)  
W [titgemeyercz.cz](http://titgemeyercz.cz)

**Titgemeyer Polska sp. z o.o.**  
Cypriana Bazylika 17  
98-200 Sieradz / PL

T +48 (0) 43 828 20 - 15  
E [sales@titgemeyer.com](mailto:sales@titgemeyer.com)  
W [titgemeyer.pl](http://titgemeyer.pl)

**Titgemeyer Skandinavien A/S**  
Lunikvej 32  
2670 Greve / DK

T +45 4360 0966  
E [info@titgemeyer.dk](mailto:info@titgemeyer.dk)  
W [titgemeyer.dk](http://titgemeyer.dk)

**Titgemeyer Skandinavien A/S**  
Box 3218  
550 03 Jönköping / SE

T +46 36 128350  
E [info@titgemeyer.se](mailto:info@titgemeyer.se)  
W [titgemeyer.se](http://titgemeyer.se)

**Titgemeyer Turkey Baglanti Teknolojileri San. ve Tic. A.S.**  
Barbaros Mah. Is Merkezi No.1  
Kat: 8 D.58

34746 Atasehir, Istanbul / TR

T +90 (0) 21 66 88 20 - 27  
E [sales@titgemeyer.com.tr](mailto:sales@titgemeyer.com.tr)  
W [titgemeyer.com.tr](http://titgemeyer.com.tr)

**Titgemeyer (UK) Limited**  
A2 Link One Industrial Park  
George Henry Road  
DY4 7BU Tipton / UK

T +44 (0) 1 21 5 57 97 - 77  
E [sales@titgemeyer.co.uk](mailto:sales@titgemeyer.co.uk)  
W [titgemeyer.co.uk](http://titgemeyer.co.uk)

### Production locations

**Baker & Finmore Limited**  
199 Newhall Street  
Birmingham, B3 1SN / UK

T +44 121 23 62 - 347  
E [info@bakfin.com](mailto:info@bakfin.com)  
W [bakfin.com](http://bakfin.com)

**Titgemeyer GmbH & Co. KG Werk Lotte**  
Daimlerstraße 13 - 15  
49504 Lotte / DE

T +49 5404 9666 - 0  
E [info@titgemeyer.com](mailto:info@titgemeyer.com)  
W [titgemeyer.com](http://titgemeyer.com)

**RIEKO GmbH**  
Robert-Bosch-Straße 9  
72124 Pliezhausen / DE

T +49 7127 9744 - 0  
E [info@rieko-web.com](mailto:info@rieko-web.com)  
W [rieko-web.com](http://rieko-web.com)

**Titgemeyer Tools & Automation spol s.r.o.**  
U Vodárny 1506  
397 01 Písek / CZ

T +42 382 2067 - 11  
E [info@rivetec.cz](mailto:info@rivetec.cz)  
W [rivetec.cz](http://rivetec.cz)

**TS Gesellschaft für Transport- und Sicherungssysteme mbH**  
Haßlinghauser Straße 156  
58285 Gevelsberg / DE

T +49 541 5822 - 900  
E [ts@cargocontrol.de](mailto:ts@cargocontrol.de)  
W [wir-sind-ladungssicherung.de](http://wir-sind-ladungssicherung.de)